

REVISIONS			
REV.	DESCRIPTION	DATE	APPROVED
A	RELEASE, SEE DCN 002775	08/01/01	

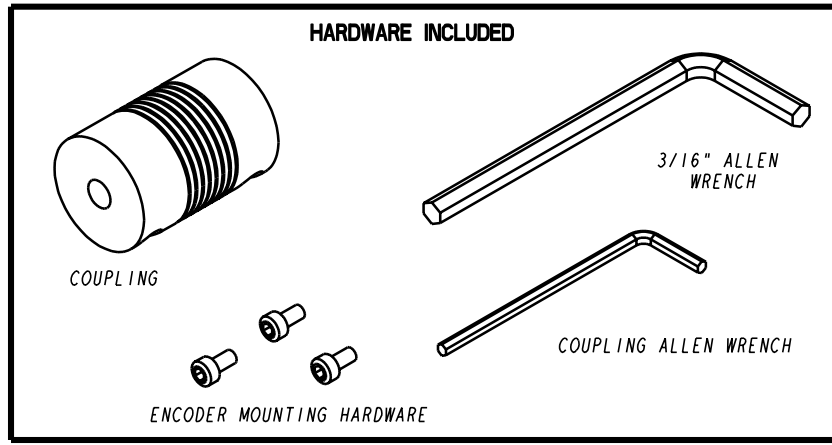
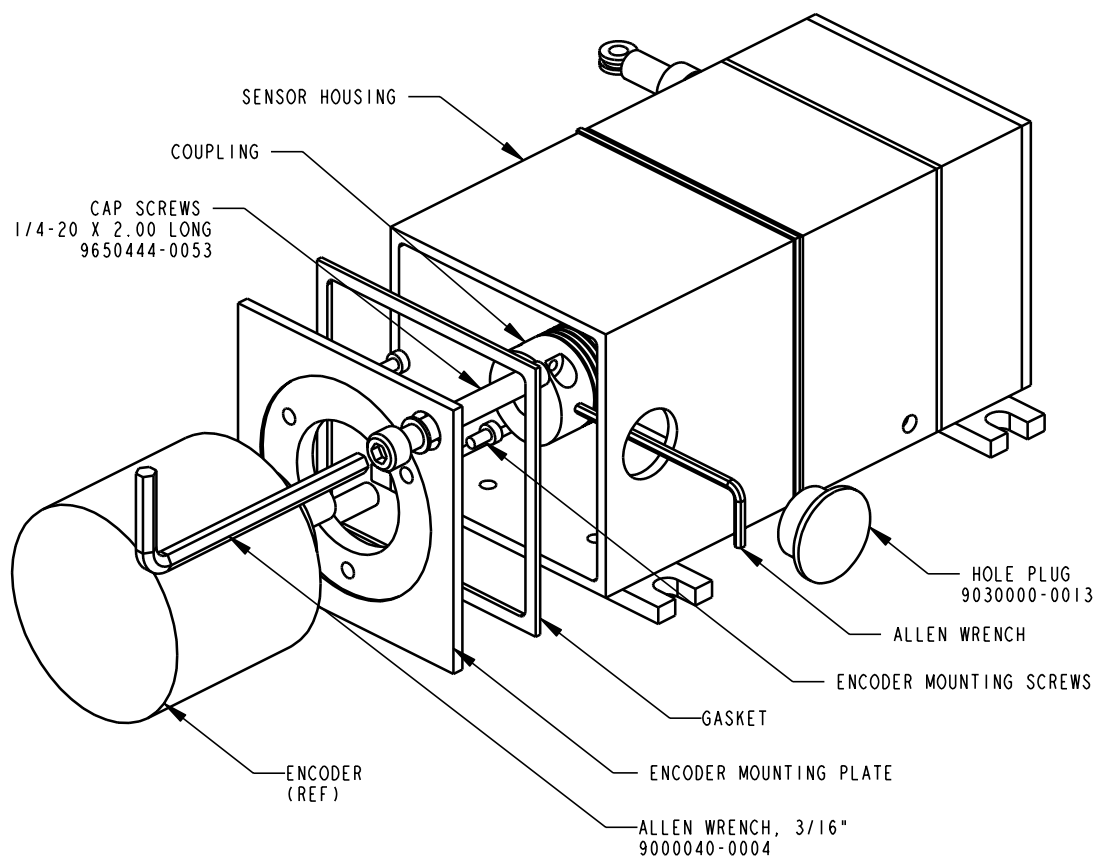

ENCODER INSTALLATION INSTRUCTIONS

1. REMOVE THE TWO 1/4-20 X 2.00 LONG CAP SCREWS USING THE 3/16" ALLEN WRENCH PROVIDED.
2. MAINTAIN SENSOR HOUSING WITH THE REST OF THE ASSEMBLY.
3. SELECT ENCODER ORIENTATION AND SCREW ENCODER TO END PLATE USING SCREWS PROVIDED.
4. REPLACE END PLATE SUB-ASSEMBLY ONTO ASSEMBLY. ASSURE GASKET SITS OVER THE END PLATE LOCATING STEP.
5. RE-INSTALL THE TWO 1/4-20 X 2.00 LONG CAP SCREWS.
6. REMOVE HOLE PLUG AND USING THE ALLEN WRENCH PROVIDED, TIGHTEN THE COUPLER SET SCREW TO ENCODER SHAFT.
7. REPLACE HOLE PLUG.

THIRD ANGLE PROJECTION		CeleSCO 7800 Deering Ave., Canoga Park, CA. 91304 TEL:(818)884-6860 Fax:(818)340-1175 Transducer Products, Inc.			
APPROVALS		DATE		TITLE	
DRAWN A. ALVAREZ		08/01/01		OUTLINE DRAWING PT5600 ENCODER INSTALLATION	
CHKD		SIZE	CODE IDENT. NO.	DWG. NO.	REV.
		B	52158	632008	A
DO NOT SCALE DRAWING		SCALE: NONE		SHEET 1 OF 1	