

REVISIONS			
REV.	DESCRIPTION	DATE	APPROVED
B	SEE DCN: 6025	12/22/07	

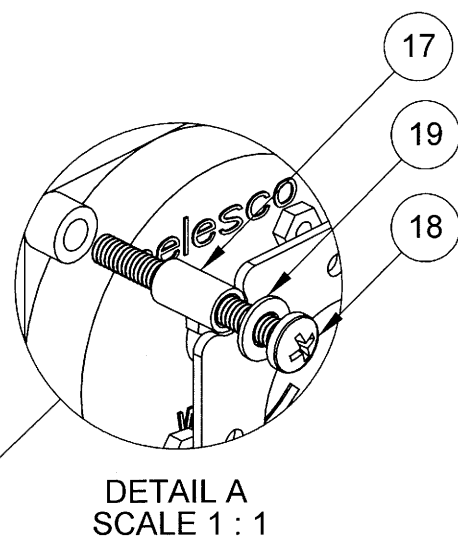

ORIGINAL

INFORMATION AND DATA SET FORTH HEREIN ARE DISCLOSED IN CONFIDENCE AND ARE PROPRIETARY TO AND THE PROPERTY OF CELESCO TRANSDUCER PRODUCTS INC. AND SHALL NOT BE USED, DUPLICATED, DISCLOSED OR TRANSFERRED, IN WHOLE OR IN PART, FOR ANY PURPOSE, WITHOUT THE EXPRESS PRIOR WRITTEN CONSENT OF CELESCO TRANSDUCER PRODUCTS INC.

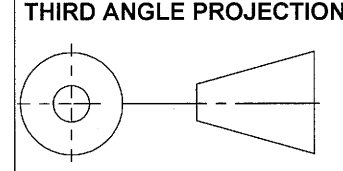

celesco
Transducer Products Inc.
20630 Plummer St
Chatsworth, CA. 91311
Tel: (818) 701-2750 Fax: (818) 701-2799
www.celesco.com

APPROVALS		DATE		TITLE	
DRAWN	A.ALVAREZ	03/01/07	SIZE	CODE IDENT. NO	DWG. NO.
CHKD	WSK	3/2/08	B	52158	PS-139
DO NOT SCALE DRAWING			SCALE: 1:1		SHEET 1 OF 6

		1	2	3	4	5	6	7	8	9	10	
		TABLE I										
		2",10",20"	5",25",50"	15",30"	40"	60"	75"	80"	100"			
A	BASEPLATE	9673968-0000				9673921-0000	9673873-0000	9673873-0000	9673554-0003			
	COVER	9673970-0001	9673971-0001	9673970-0002	9676338-0000	9673920-0000	9673872-0000	9673872-0000	9673902-0003			
	FRAME	9673966-0003	9673967-0002	9673966-0004	9676285-0001	9674184-0002	9673858-0001	9673858-0001	9673547-0001			
	SPOOL	9678341-0001	9678341-0004	9678341-0002	9678341-0003	9674185-0000	9673859-0000	9674322-0000	9673548-0000			
	PLATE,POT MNTG	9673532-0001					9673871-0001	9673871-0001	9673546-0001			
	PLATE,SPG MNTG	9673531-0001					9673862-0001	9673862-0001	9673545-0001			
	SPRING ASSY	9603570-0000					9603571-0000	9603571-0000	9603614-0000			

B				
C	28	9000410-0001	BEARING .375X.875,PER DWG 650491	2
	27	SEE SHEET 4	CONNECTOR + MATING CONNECTOR	1
	26	9000320-0003	GASKET,RUBBER,PSNXDCR	AR
	25	9007121-4405	MSCR CRES 0.112-40X0.25 XRSPNH	2
	24	9650444-0193	MSCR CRES 0.164-32X0.31 XRSFLH	2
	23	9011264-4404	SSCR,0.112-40X3/16,SKT HD,BLOX CONE PNT	2
	22	9650444-0216	CSCR .164-32X.44 SKT HD, ST STL	2
	21	9007121-4406	MSCR CRES 0.112-40X0.31 XRSPNH	4
	20	9001221-4411	NUT CRES 0.112-40 HEX	4
	19	9000400-0216	WASHER,SHIM,0.030THK,CRES	
D	18	9650444-0233	MSCR CRES 0.164-32X1.00 XRSPNH (100 IN)	2
		9650444-0192	CSCR CRES 0.164-32X1.12 SKTHD (75-80 IN)	
		9007121-8317	MSCR CRES 0.164-32X1.38 XRSPNH (2-60 IN)	
E	17	9013113-320C	0.813 LG (100 IN)	2
		9013113-3206	0.437 LG (2 -80 INCH)	
	16	9650444-0121	MSCR,CRES 0.112-40X0.75 XRSPNH	2
	15	9013113-1207	SPACER,RND,AL,0.12 ID, X 0.50 LG	2
		14	9603755-XXXX 	SUBASSEMBLY, CABLE,0.019 PER 603755
F	13	9676792-0000	GUIDE,CABLE,MOLDED NYLON	1
	12	9673874-0000	PLATE,POT-MTG,PSNXDCR,MSTC	1
	11	SEE TABLE II	POTENTIOMETER	1
	10	9674784-0000	PLATE,TACH-MTG,VELXDCR,MSTC	1
	9	9674540-0001	TACHOMETER,MOD,7V/1000 RPM	1
	8	9000400-0173	WASHER,SHIM,10X16X0.3,ST STL	1
	7	SEE TABLE I	SUBASSY,SPRING,PSNXDCR,DV301	1
	6	SEE TABLE I	PLATE,SPG-MNTG	1
	5	SEE TABLE I	PLATE,POT-MNTG	1
	4	SEE TABLE I	SPOOL	1
G	3	SEE TABLE I	FRAME	1
	2	SEE TABLE I	COVER	1
	1	SEE TABLE I	BASEPLATE	1
	ITEM NO	PART NUMBER	DESCRIPTION	QTY

TABLE II (POTENTIOMETER)				
RANGE	500 Ω	1K Ω	5K Ω	10K Ω
2"	9083000-0052 (1 TURN)	9083000-0025 (1 TURN)	9080000-0001 (1 TURN)	9080000-0003 (1 TURN)
5"				
10"	9085000-0004 (5 TURN)	9085000-0011 (5 TURN)	9085000-0013 (5 TURN)	9085000-0001 (5 TURN)
15"				
20"	9085000-0003 (10 TURN)	9085000-0006 (10 TURN)	9085000-0010 (10 TURN)	9085000-0002 (10 TURN)
25"				
30"	9085000-0003 (10 TURN)	9085000-0006 (10 TURN)	9085000-0010 (10 TURN)	9085000-0002 (10 TURN)
40"				
50"				
60"				
75"				
80"				
100"				

ORIGINAL

 DASH NUMBER OF CABLE ASSEMBLY EQUALS THE RANGE OF THE TRANSDUCER IN INCHES.

INFORMATION AND DATA SET FORTH HEREIN ARE DISCLOSED IN CONFIDENCE AND ARE PROPRIETARY TO AND THE PROPERTY OF CELESCO TRANSDUCER PRODUCTS INC. AND SHALL NOT BE USED, DUPLICATED, DISCLOSED OR TRANSFERRED, IN WHOLE OR IN PART, FOR ANY PURPOSE, WITHOUT THE EXPRESS PRIOR WRITTEN CONSENT OF CELESCO TRANSDUCER PRODUCTS INC.

THIRD ANGLE PROJECTION

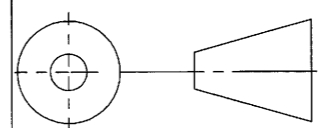

celesco 20630 Plummer St
Chatsworth, CA. 91311
Tel:(818)701-2750 Fax:(818)701-2799
www.celesco.com

Transducer Products Inc.

TITLE
ASSEMBLY DRAWING
DV301-2 IN THRU 100 IN

APPROVALS	DATE	SIZE	CODE IDENT. NO	DWG. NO.	REV
DRAWN A.ALVAREZ	03/01/07	B	52158	PS-139	B
CHKD <i>MSK</i>	7/2/08	DO NOT SCALE DRAWING		SCALE: 4:1	SHEET 2 OF 6

	RANGE (INCHES)	SPRING WINDINGS
A	2 IN	8
	5 IN	8
	10 IN	8
	15 IN	8
	20 IN	8
B	25 IN	8
	30 IN	8
	40 IN	8
	50 IN	8
	60 IN	8
	75 IN	7
	80 IN	7
	100 IN	4

SPRING WINDINGS ARE TOTAL NUMBER OF SPRING TURNS AFTER MEASURING CABLE HAS BEEN FED INTO SPOOL.

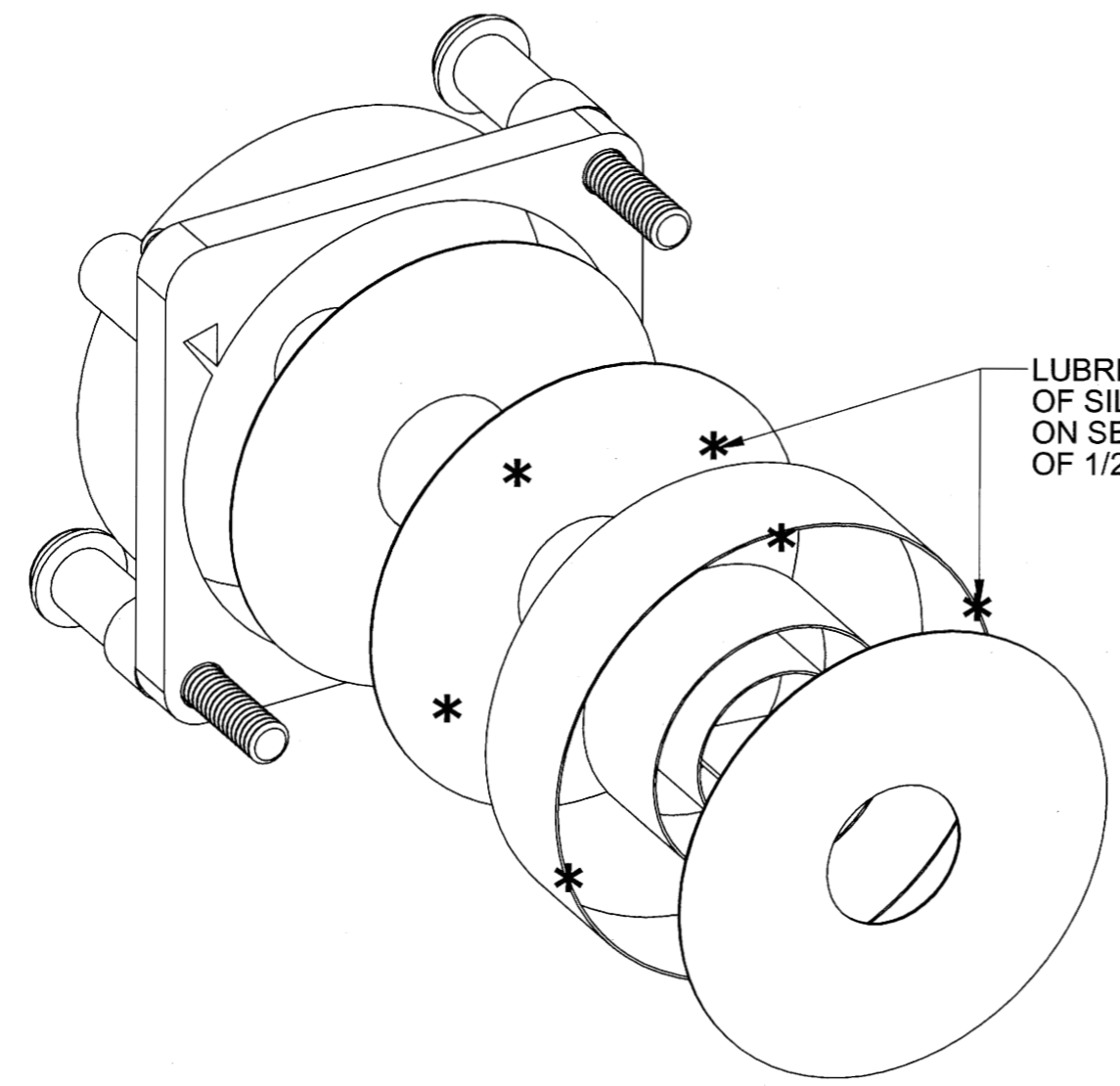

LUBRICATE SPRING BY APPLYING 1/4 CC OF SILICONE OIL P/N: 9000000-0001 ON SELECTED SURFACES, FOR A TOTAL OF 1/2 CC, AS SHOWN

ORIGINAL

INFORMATION AND DATA SET FORTH HEREIN ARE DISCLOSED IN CONFIDENCE AND ARE PROPRIETARY TO AND THE PROPERTY OF CELESCO TRANSDUCER PRODUCTS INC. AND SHALL NOT BE USED, DUPLICATED, DISCLOSED OR TRANSFERRED, IN WHOLE OR IN PART, FOR ANY PURPOSE, WITHOUT THE EXPRESS PRIOR WRITTEN CONSENT OF CELESCO TRANSDUCER PRODUCTS INC.

THIRD ANGLE PROJECTION

celesco 20630 Plummer St
Chatsworth, CA. 91311
Tel:(818)701-2750 Fax:(818)701-2799
www.celesco.com

Transducer Products Inc.

TITLE
ASSEMBLY DRAWING
DV301-2 IN THRU 100 IN

APPROVALS		DATE	SIZE	CODE IDENT. NO	DWG. NO.	REV
DRAWN	A.ALVAREZ	03/01/07	B	52158	PS-139	B
CHKD	MSK	3/2/08	DO NOT SCALE DRAWING		SCALE: 4:1	SHEET 3 OF 6

1 USE PRO RIVET GUN P/N: 9610053-0000.

A
B
C
D
E
F
G

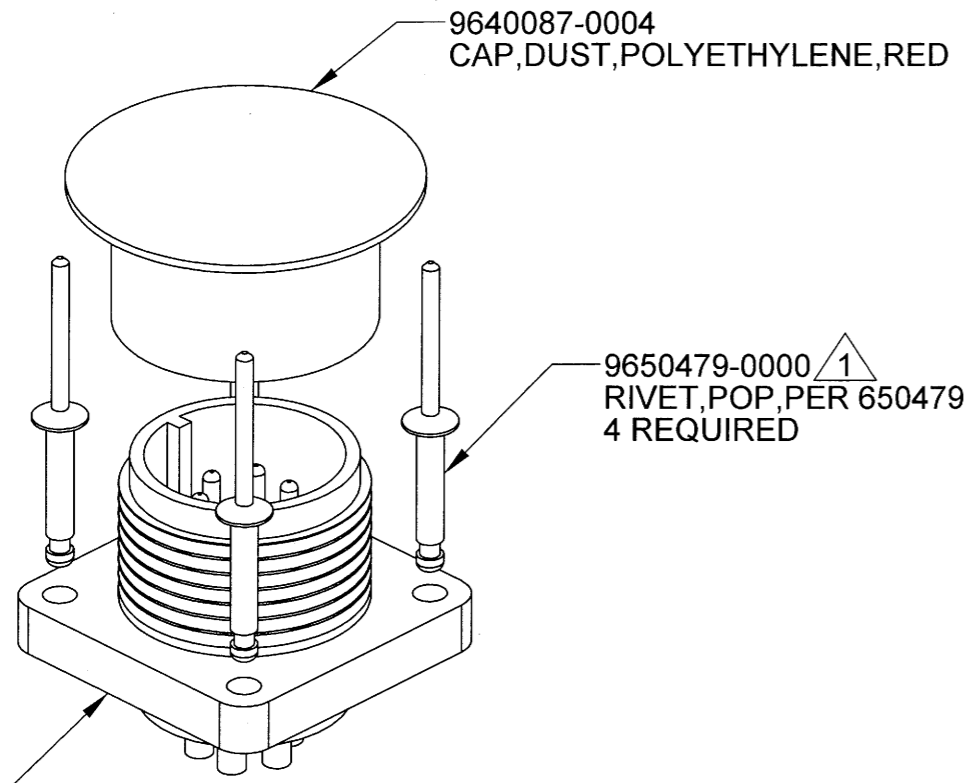

9035830-0001
CONN, RCPT, BOX-MTG, 14SHELL, 6PIN
MATES WITH:
CONN, PLUG, STR, 14 SHELL, 6 SKT
9036830-0001

(NYLON CONNECTOR)

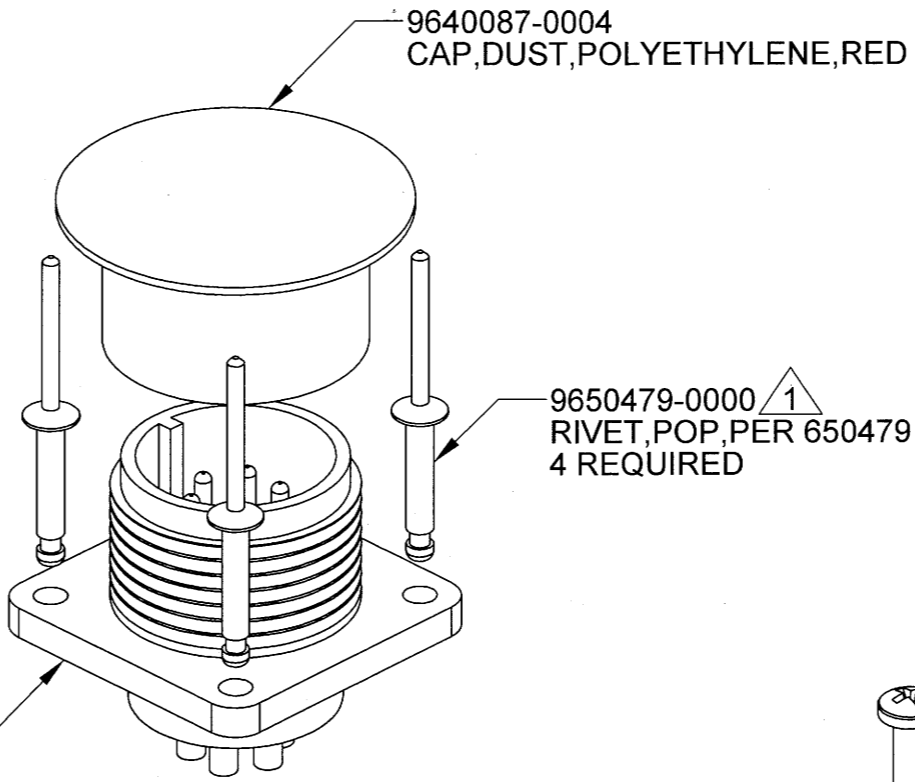

9035810-0001
CONN, RCPT, BOX-MTG, 14SHELL, 6PIN
MATES WITH:
CONN, PLUG, STR, 14 SHELL, 6 SKT
9036810-0001

(METAL CONNECTOR)

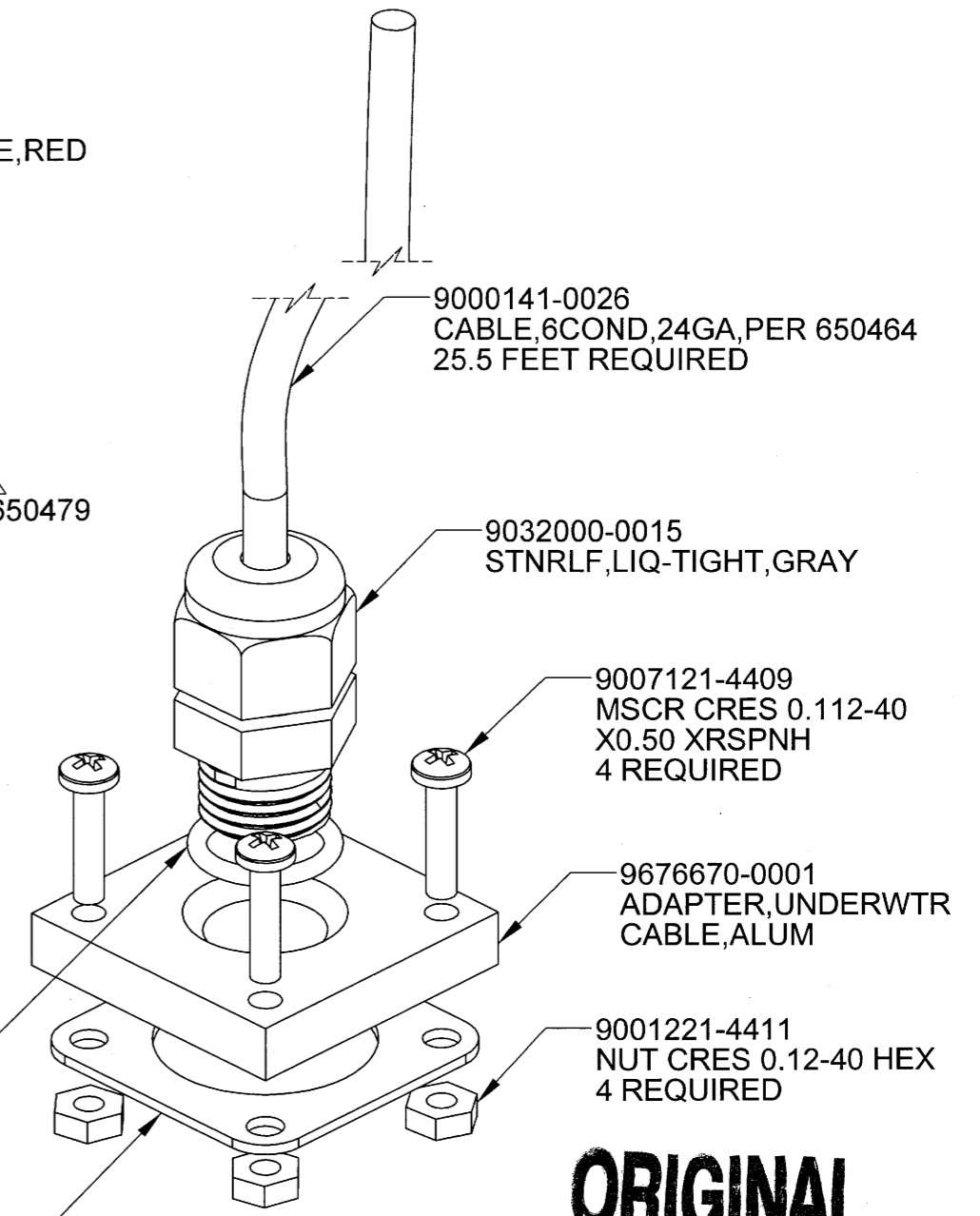

9000312-0131
SEAL, O'RING,
NITRILE, 0.426 ID

9000320-0006
GASKET, FLANGED
CONN, 14 SHELL

9000141-0026
CABLE, 6COND, 24GA, PER 650464
25.5 FEET REQUIRED

9032000-0015
STNRLF, LIQ-TIGHT, GRAY

9007121-4409
MSCR CRES 0.112-40
X0.50 XRSPNH
4 REQUIRED

9676670-0001
ADAPTER, UNDERWTR
CABLE, ALUM

9001221-4411
NUT CRES 0.12-40 HEX
4 REQUIRED

ORIGINAL

(25FT INSTRUMENTATION CABLE)

	DV301				
	POTENTIOMETER			TACH	
	CCW	CW	S	+OUT	-OUT
6 PIN CONNECTOR	A	B	C	E	F
INSTRUMENTATION CABLE	RED	BLACK	GREEN	WHITE	BROWN

INFORMATION AND DATA SET FORTH HEREIN ARE DISCLOSED IN CONFIDENCE AND ARE PROPRIETARY TO AND THE PROPERTY OF CELESCO TRANSDUCER PRODUCTS INC. AND SHALL NOT BE USED, DUPLICATED, DISCLOSED OR TRANSFERRED, IN WHOLE OR IN PART, FOR ANY PURPOSE, WITHOUT THE EXPRESS PRIOR WRITTEN CONSENT OF CELESCO TRANSDUCER PRODUCTS INC.

THIRD ANGLE PROJECTION

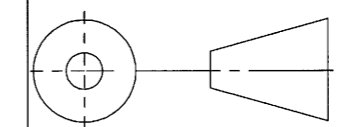

celesco 20630 Plummer St
Chatsworth, CA. 91311
Tel: (818) 701-2750 Fax: (818) 701-2799
www.celesco.com

TITLE
**ASSEMBLY DRAWING
DV301-2 IN THRU 100 IN**

APPROVALS	DATE	SIZE	CODE IDENT. NO	DWG. NO.	REV
DRAWN A. ALVAREZ	03/01/07	B	52158	PS-139	B
CHKD <i>MSK</i>	<i>2/2/08</i>	DO NOT SCALE DRAWING		SCALE: 2:1	SHEET 4 OF 6

A

B

C

D

E

F

G

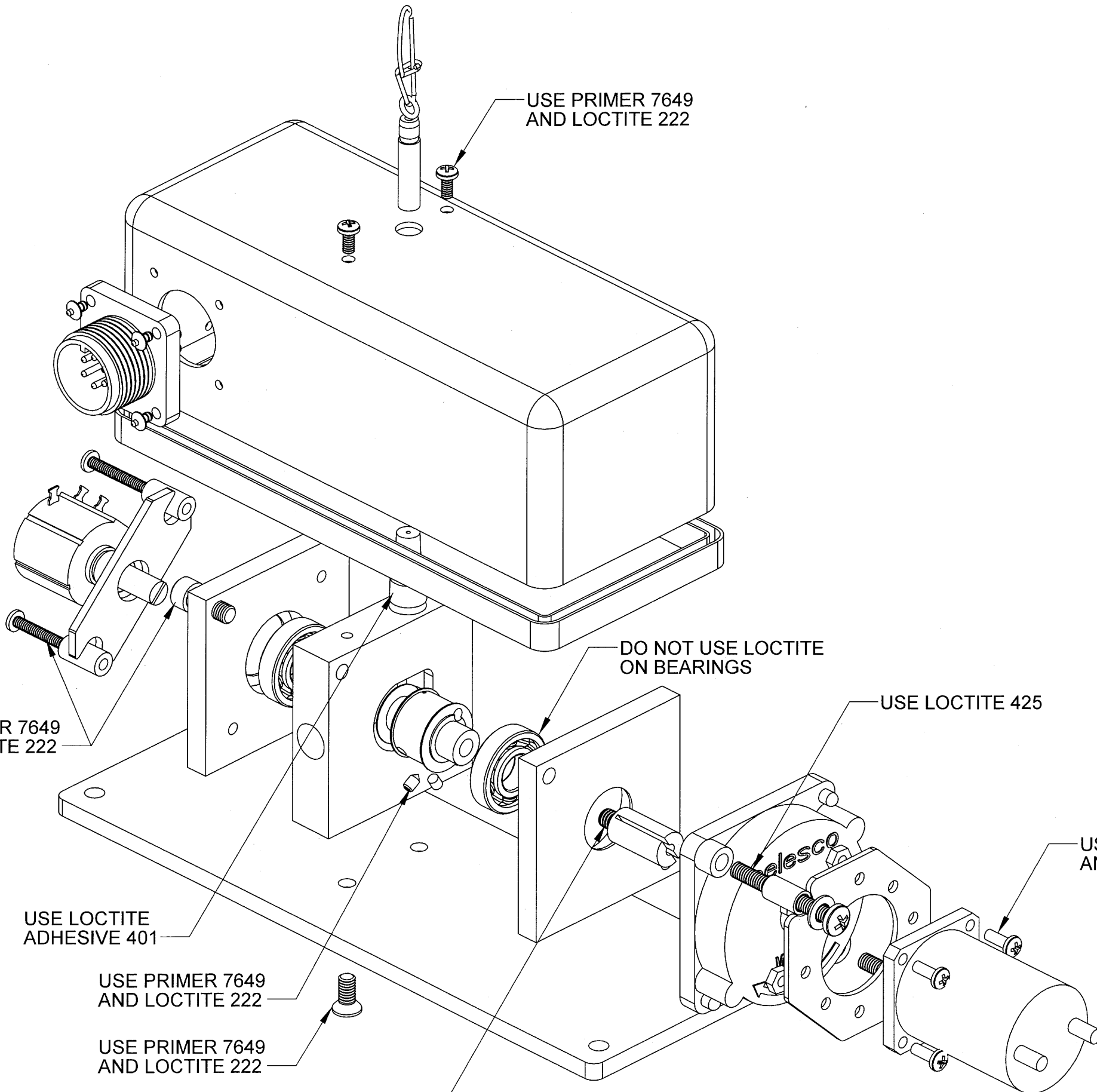

USE PRIMER 7649 AND LOCTITE 222

DO NOT USE LOCTITE ON BEARINGS

USE LOCTITE 425

USE PRIMER 7649 AND LOCTITE 222

USE PRIMER 7649 AND LOCTITE 222

USE LOCTITE ADHESIVE 401

USE PRIMER 7649 AND LOCTITE 222

USE PRIMER 7649 AND LOCTITE 222

USE PRIMER 7649 AND LOCTITE 222

ORIGINAL

INFORMATION AND DATA SET FORTH HEREIN ARE DISCLOSED IN CONFIDENCE AND ARE PROPRIETARY TO AND THE PROPERTY OF CELESCO TRANSDUCER PRODUCTS INC. AND SHALL NOT BE USED, DUPLICATED, DISCLOSED OR TRANSFERRED, IN WHOLE OR IN PART, FOR ANY PURPOSE, WITHOUT THE EXPRESS PRIOR WRITTEN CONSENT OF CELESCO TRANSDUCER PRODUCTS INC.

THIRD ANGLE PROJECTION

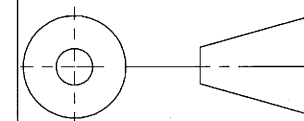

celesco 20630 Plummer St
Chatsworth, CA. 91311
Tel: (818) 701-2750 Fax: (818) 701-2799
www.celesco.com

TITLE
**ASSEMBLY DRAWING
DV301-2 IN THRU 100 IN**

APPROVALS		DATE	SIZE	CODE IDENT. NO	DWG. NO.	REV
DRAWN	A. ALVAREZ	03/01/07	B	52158	PS-139	B
CHKD	NSK	7/2/08	DO NOT SCALE DRAWING		SCALE: 4:1	SHEET 5 OF 6

